

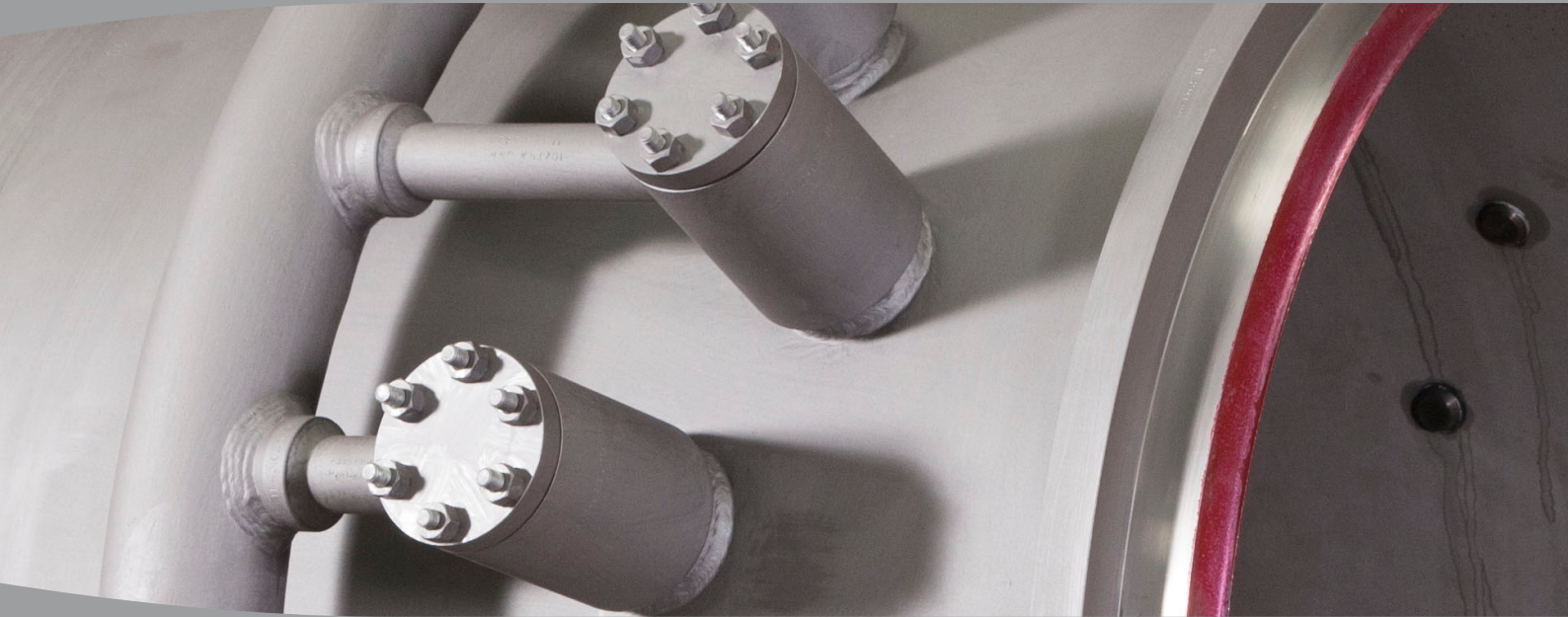

BOMAF[®]
Special Valve Solutions

www.bomafa.de



Desuperheaters

- Customized designs for each application
- Stable temperature control
- Efficient vaporization
- Avoidance of thermal stress

BOMAF Valves



Power



Chemistry



Industry

BOMAF develops and produces high-quality valves for steam, gas and water. The valves are used in nearly all kinds of power plants, chemical and petrochemical plants and a range of various other industrial applications.

BOMAF A Desuperheaters

Stable temperature control and high reliability

Processes in the chemical and petrochemical industry as well as in power plants require hot steam with well-defined parameters.

When it is taken out of a different another process, it must be regulated in accordance to the required pressure and temperature.

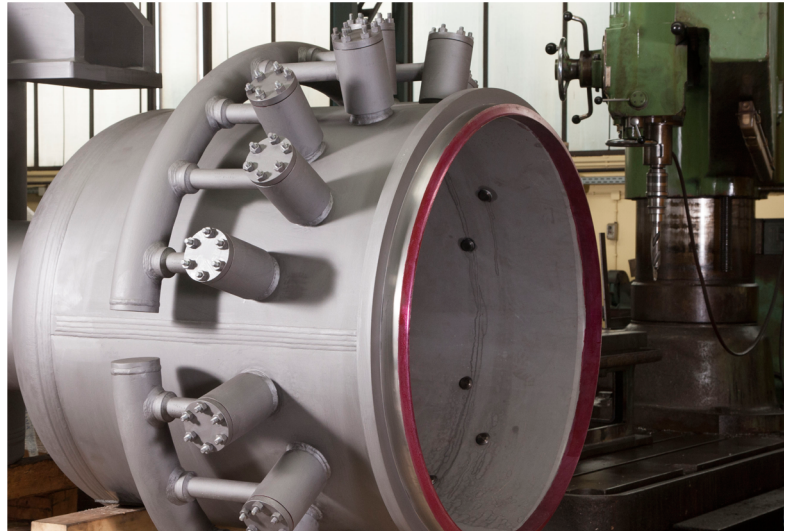

Desuperheaters conduct the cooling of the steam in the pipe. The injection of cooling water is preferably carried out by BOMAF A desuperheaters in the region of the smallest flow cross-section, with correspondingly highest steam velocities.

Due to the streamlined design, unintended pressure losses are effectively prevented. Therefore: The more accurate the steam control, the more economical the result of the entire process.

Desuperheaters for each application

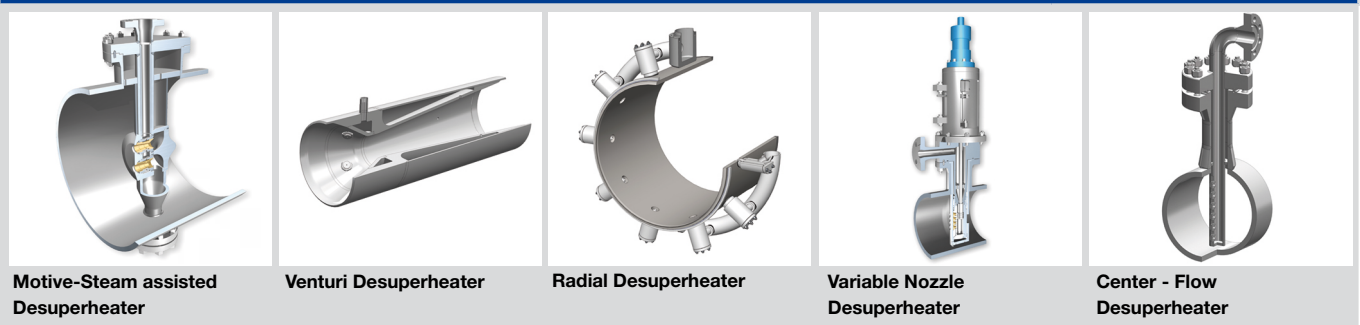

Customized design

From BOMAF A you get desuperheaters, precisely designed for your application. With the adequate type of injection, a high vapor quality is achieved as well as avoidance of down-time costs.

Motive-Steam assisted Desuperheater

Desuperheating close to saturation temperature at minimal loads

At the motive steam assisted desuperheater, the atomization of water is achieved by separately supplied atomizing or motive steam at high pressure.

The motive steam is passed at high speed through the nozzle and cooling water injection. There it tears the injected water immediately into very fine droplets.

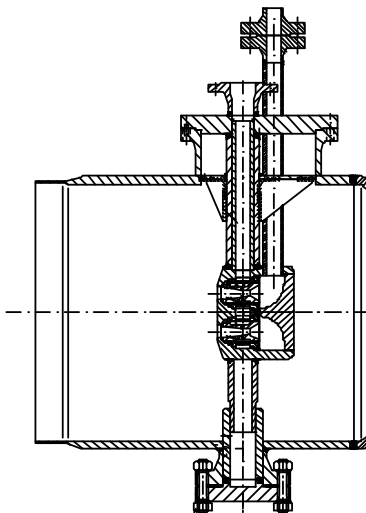
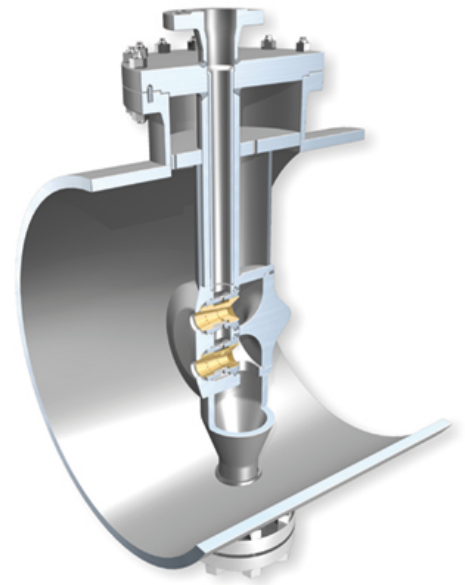

A motive steam nozzle is often positioned directly behind a pressure reduction system. It is taken from the high pressure side. Otherwise motive steam must be supplied from an outside source.

The motive steam with its correspondingly high pressure leads under optimized geometrical conditions to very high relative velocities between water droplets and vapor.

Design Features

Vaporization assisted by motive steam

Best mixing of steam and water, even at minimal loads of 5%

Very short vaporization distances

Data: Motive-Steam assisted Desuperheater

DN of steam line	from DN 100
DN of motive steam line	from DN 25
DN of water line	from DN 15
Connection of Desuperheater to steam line	BWE or flange
Connection of Desuperheater to water line	BWE or flange
No. of nozzles	1 bis 3
Min. steam velocity	no limit
Turndown ratio	1 : 25

Venturi Desuperheater

Highest controllability at low steam velocities

By reducing the pipe cross-section, Venturi desuperheaters increase steam velocities which lead to greater turbulence and therefore to improved mixing behavior. The diameter of the pipe is approximately halved.

An efficient evaporation of the injection water and short evaporation distances even at low vapor velocity are characteristics of this desuperheater. End temperatures of 6-8 C° above saturated steam temperature can be obtained.

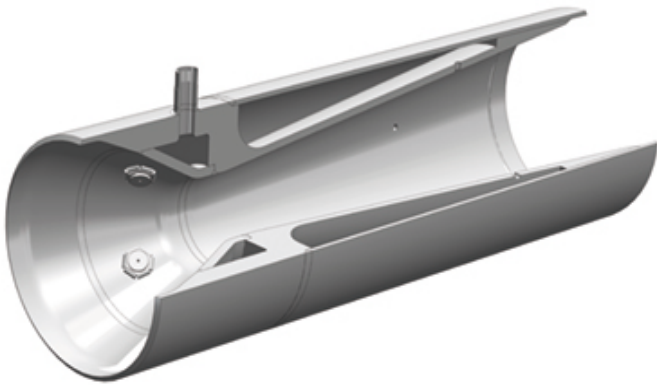

The application range of Venturi desuperheaters reaches from DN 40 to DN 300. A hollow cone nozzle or an annular chamber is used for water for injection at the lowest point of the cross section, where highest turbulences in the steam flow occur.

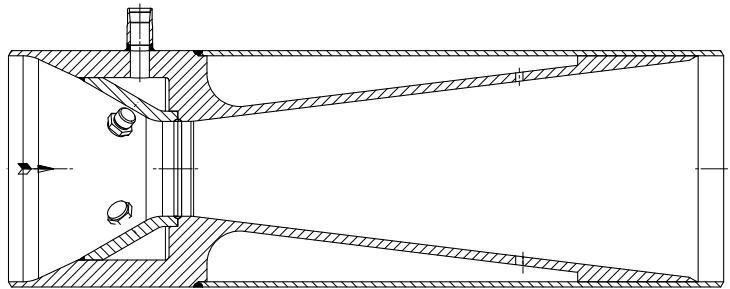

Design Features

Control of a wide load range from 10 to 100% of maximum steam capacity

No installations in steam flow required

Minimized pressure drop

Data: Venturi Desuperheater

DN of steam line	DN 40 to DN 300
DN of water line	from DN 15
Connection of Desuperheater to steam line	BWE or flange
Connection of Desuperheater to steam line	BWE or flange
Type of injection	Annular gap or hollow cone nozzles
Min. steam velocity	no limit
Turndown ratio	1 : 10

Radial Desuperheater

Injection of large water volumes

Radial desuperheaters are based on the principle of pressurized atomization. Through the use of connected individual nozzles they are particularly suitable for the injection of large volumes of water at low-costs.

The individual nozzles are connected with a ring line. The control of water injection into the steam line is achieved by a separate water - injection control valve and the spring loading of the individual nozzles.

Each nozzle is exchangeable which guarantee very fast and easy service works. The radiator is welded as a unit into pipes.

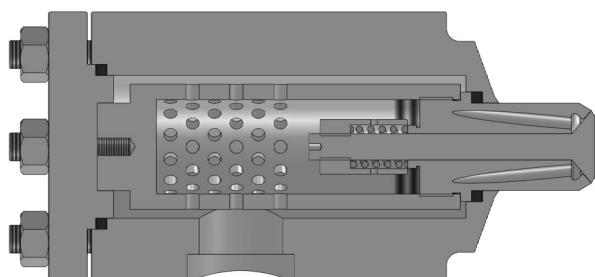
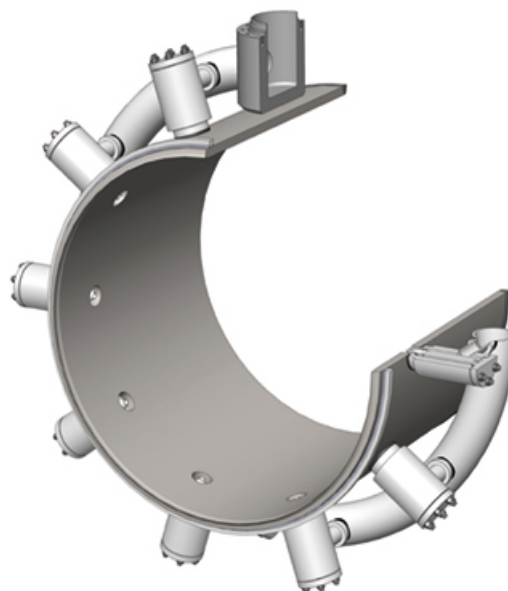

Special nozzles

By specific characteristics of the spring gap openings in the nozzles, the injection water can be sprayed effectively even at low pressure differences.

Design Features

Spring-loaded, individually replaceable nozzles

Even injection into the evaporation chamber

Avoidance of superimposed spray patterns

Data: Radial Desuperheater

DN of steam line	from DN 200
DN of water line	from DN 25
Connection of Desuperheater to steam line	BWE or flange
Connection of Desuperheater to steam line	BWE or flange
No. of nozzles	3 - 24
Min. steam velocity	8 m/s
Turndown ratio	1 : 4

Variable Nozzle Desuperheater

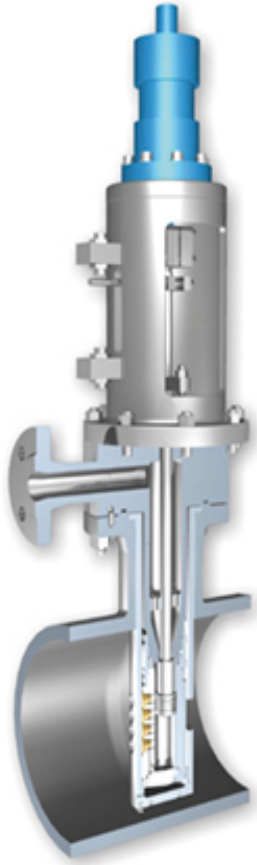

Highest controllability at a wide load range

Variable nozzle injection desuperheaters are used when precise control over a wide load range is required.

The injected volume of water is regulated by controlled opening and closing of the single nozzles. The water pressure is held constant, so that variations in the pressure difference to the steam and related large water drops can be effectively prevented.

Integrated Water - injection Control Valve

Variable nozzle desuperheaters form a unit of integrated water valve and injection system.

The individual nozzles can be opened and closed by a movable piston with a wear-resistant seal.

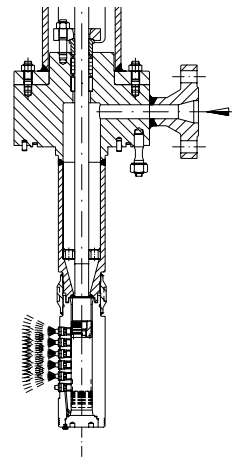

Design Features

- Exactly control of each nozzle possible
- Wear-resistant sealing of all control elements
- Contains integrated control valve for cooling water injection

Data: Variable Nozzle Desuperheater

DN of steam line	from DN 200
DN of water line	from DN 15
Connection of Desuperheater to steam line	Probe type, flanged
Connection of Desuperheater to steam line	Flange
Type of nozzles	Hollow cone nozzles
No. of nozzles	1 - 6
Min. steam velocity	8 m/s
Turndown ratio	1 : 12

Center-Flow Desuperheater

Superheated steam at narrow load range

The Center Flow desuperheater is preferably used for cooling in temperature ranges well above the saturated steam line and at narrow load ranges. As a service-friendly probe type desuperheater, it is flanged to water and steam pipe.

For the pressurized atomization, the water is injected by special atomizing nozzles centrally into the stream flow.

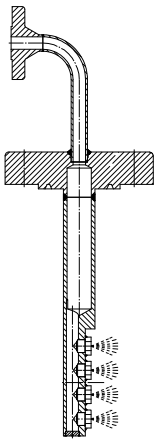

Mostly hollow cone nozzles are used where the water is brought into a twist by a special geometry of the nozzles and the pressure difference between the steam and water. The water is circularly atomized by the centrifugal force into fine droplets.

An upstream water - injection control valve regulates the water supply.

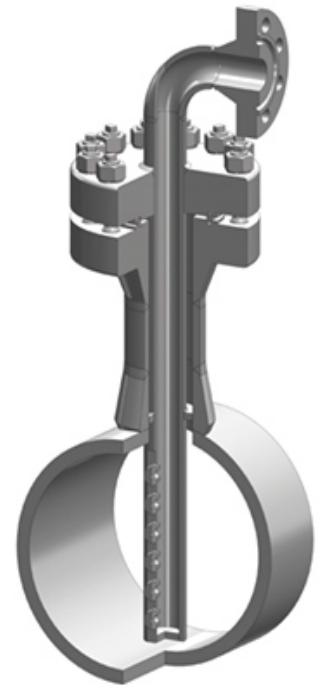

Design Features

Injection takes place centrally in the vapor stream (Center Flow)

Control of cooling water injection through upstream control valve

Verschleißresistente, modulare Bauweise

Data: Center-Flow Desuperheater

DN of steam line	from DN 80
DN of water line	from DN 15
Connection of Desuperheater to steam line	Probe type, flanged
Connection of Desuperheater to steam line	Flange
Type of nozzles	Hollow cone nozzles
No. of nozzles	1 - 6
Min. steam velocity	8 m/s
Turndown ratio	1 : 4